

Client _____ Quantity _____
Project _____ Position _____

Levtronic 900 cabinet

Model: A90/1FH

Cod: A32090800101



Technical data

Max capacity:	34 trays EN60x80
Gross capacity:	872 lt
Temperature range:	-6°+40°C
Ventilation range:	25% - 100%
Humidity range:	45% - 95% with humidifier
Humidifier:	Including
Refrigerant unit:	Plug-in
Energetic class:	E
Energy efficiency index:	77
Annual consumption:	1261 kW/h annum
24h consumption:	3,454 kW/h/24h
Climate class:	5
Cooling gas:	R290
Defrost:	Hot gas
Valve:	Supplied standard with solenoid
Dimensions (mm):	810×1015×2085 mm
Packing dimensions:	905×1130×2258 mm
Gross weight:	185 Kg
Voltage:	220-240 V - 50 Hz
Total rate:	1360 W
Absorbed Current:	6,2 A

Features

Functions:	Manual proving, retarder prover, continuous cycle, storage
Standard equipment:	20 slides for EN60x80 trays, lock with key, LED lighting, water drain
Control:	4,3" touch screen display with USB port
Doors:	1 door, self-closing with a 105° stop, right hinged
Door gasket:	Magnetic, triple chamber and easily replaceable
Insulation:	75 mm thickness - CFC/HCFC free
Exterior/interior finishing:	Exterior and interior AISI 304 stainless steel. Back, base and internal technical compartment in galvanized/colaminated steel.
Inner corners:	Rounded for easy cleaning and ensuring maximum hygiene
Handle:	Stainless steel AISI 304, 2 mm thick
Racks and slides:	Stainless steel AISI 304
Feets:	AISI 304 stainless steel adjustable h 100/150 mm
Cosmo:	Wi-Fi remote control system

Accessories and variants

- RAL customisable colouring
- Stainless steel evaporator
- Power supply frequency 60Hz
- Other special voltage
- Kit für Öffnung der Tür mit Pedal
- Purity C Quell ST 50 filter cartridge
- Aluminium coated backing-pan EN60x40 h 20 mm
- Stainless steel shelf EN60x40
- Plastic coated shelf EN60x40
- Pair of type L slides 755 mm EN60x80
- Serial interface, RS485 cable

COSMO - wi-fi control

Cosmo is the wi-fi technology that allows LEVTRONIC retarder provers to be connected, updated and monitored from smartphones. LEVTRONIC is also a Cosmo hub and allows remote supervision of the Coldline appliances connected to it. From the CosmoApp you can check the operating conditions of each machine and receive alerts in the event of abnormal operation.

Technical draw

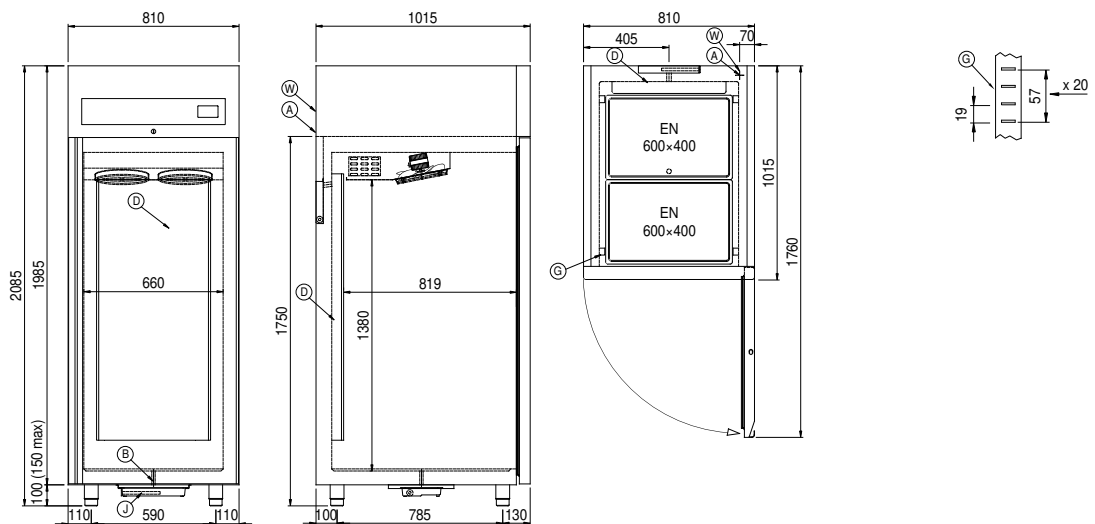

- | | | |
|-------------------------------------|---|---|
| A: Power supply cable outlet | B: Condensation water drain | D: Airflow conveyor |
| G: Racks pitch | J: Automatic evaporation of condensing water | W: Water mains connection for humidifier - 3/4" female. Unloading not required |

In order to constantly offer the best possible products we reserve the right to make changes on technical specifications without incurring any obligation for equipment previously or subsequently sold.