

Fast and energy saving

TDR 8 Programmable

The Turbo Deli Rotisserie is the fastest original rotisserie in the industry! The double-loop airflow heats the entire cavity in a very efficient way, preparing your products up to 30% faster than conventional rotisseries. The TDR uses fresh air, roasting a rotisserie chicken as it is meant to be: crispy and delicious while maintaining an attractive appearance for hours.

The TDR pushes the air throughout the cavity, resulting in an improved heat transfer on the products and consequently in a reduced electricity consumption during the preparation process. **Thanks to Eco Cooking the TDR saves 5% additional energy.** Add to this the improved heat transfer on the products and a fast preparation process and you have yourself the most energy-efficient rotisserie with a high output.

Cook Correction corrects alterations in the cooking cycle that are due to half-loads, overloads, or products with a difference in temperature. It measures abnormalities in the temperature curve and corrects the cycle automatically, ensuring food-safety and energy-efficient cooking.



Programmable controls



Matching stand on castors (optional)



Ventless hood (optional)



Also available: Stacked TDR 8 + 8 P



Features TDR 8 Programmable

Top features

- Controls with programmable settings - easy, consistent operation
- Cook Correction detects and corrects abnormalities during the cook cycle
- Eco Cooking uses residual heat during the last part of the cook cycle
- Endless possibilities: poultry (parts), pork roast, ribs, lamb, roast beef, pork belly, meat loaf, porchetta and other proteins

Standard characteristics

- 8 Meat fork, V-spit, basket or rack positions
- Rotor for up to 40 chickens (1,2 kg)
- 99 programs with up to 3 cook stages per program
- USB connection for easy transfer of data and programs

Accessories

- Meat forks (included)
- Multi-purpose baskets
- V-spits
- Chicken racks
- Matching stand on castors

Optional

- Stacked unit 8 + 8 P
- Door handle set for pass through operation
- Flexible positioning with ventless hood

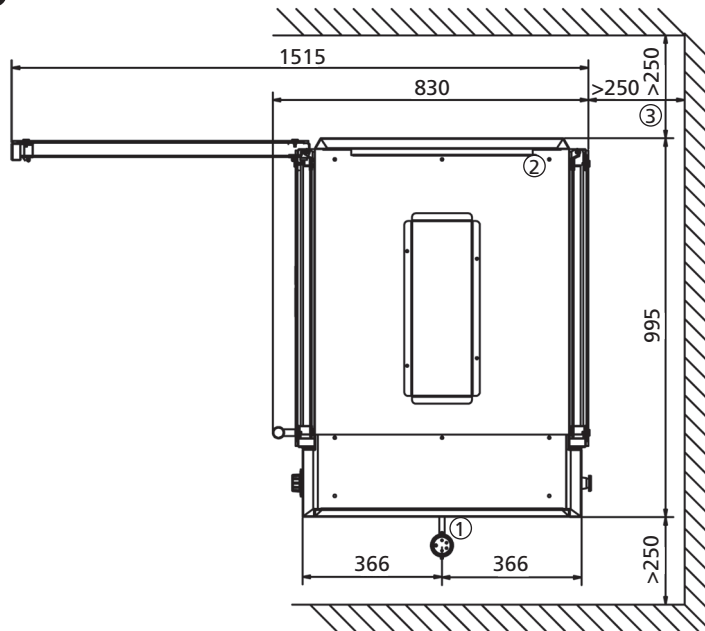

TDR 8 Programmable

- 1 Power cable 2.2 m
- 2 Exhaust opening
- 3 Space to the wall
- 4 Location for socket

Dimensions TDR 8

Width	995 mm
Depth	830 mm
Depth with hood	970 mm
Height	1065 mm
Height on stand	1796 mm
Height with hood	1395 mm

Technical data TDR 8

Net weight	185 kg
Gross weight	216 kg
Voltage	3N~ 400/230 V
Frequency	50/60 Hz
Power	10.5 kW

Dimensions TDR 8 + 8 P

Width	995 mm
Depth	830 mm
Depth with hood	970 mm
Height	2095 mm
Height with hood	2344 mm

Technical data TDR 8 + 8 P

Net weight	375 kg
Gross weight	435 kg
Voltage	3N~ 400/230 V
Frequency	50/60 Hz
Power	21 kW

Specifications and technical data are subject to amendment without prior notice.

These are basic drawings. For more detailed technical information, please refer to the installation manual at www.frijado.com.

