

Client _____ Quantity _____
 Project _____ Position _____

Vision F Blast Chiller Counter

Model: WTP7F **Cod:** W67073011001



Technical data

Top:	Thickness 4 cm. Reinforced in order to place an oven
Max capacity:	11 trays GN1/1, EN60x40 h 20 mm
Gross capacity:	248 lt
Temperature range:	-40°+65°C
Ventilation range:	25% - 100%
Humidity range:	45% - 95% with humidifier
Humidifier:	Including
Refrigerant unit:	Plug-in
Yield +90 / +3:	34 Kg
Yield +90 / -18:	24 Kg
Climate class:	5
Cooling gas:	R452a
Defrost:	Hot gas
Body height:	710 mm
Valve:	Electronic expansion valve
Dimensions (mm):	1400×700×850 mm
Packing dimensions:	1545×900×998 mm
Gross weight:	170 Kg
Voltage:	220-240 V - 50 Hz
Total rate:	1950 W

Features

Functions:	Blast chilling, shock freezing, thawing, proving and retarder prover, holding, desiccation, chocolat
Standard equipment:	7 slides GN1/1, EN60x40
Control:	7" touch screen display with USB port
Door gasket:	Magnetic, triple chamber and easily replaceable
Core probe:	Needle probe with 1 reading point, quick-release and easily replaceable
Insulation:	60 mm thickness - CFC/HCFC free
Exterior/interior finishing:	Exterior and interior AISI 304 stainless steel. Internal and external in "linen canvas" steel
Inner corners:	Rounded for easy cleaning and ensuring maximum hygiene
Handle:	Stainless steel AISI 304, 2 mm thick
Racks and slides:	Stainless steel AISI 304, quick release
Feets:	AISI 304 stainless steel adjustable h 100/150 mm
Cosmo:	Wi-Fi remote control system

In order to constantly offer the best possible products we reserve the right to make changes on technical specifications without incurring any obligation for equipment previously or subsequently sold.

Accessories and variants

- _____ RAL customisable colouring
- _____ Sonda al cuore a 3 punti di lettura
- _____ Sonda al cuore riscaldata a 1 punto di lettura
- _____ Inversione apertura porta
- _____ Power supply frequency 60Hz
- _____ Other special voltage
- _____ Purity C Quell ST 50 filter cartridge
- _____ Lowered foot h 55/70 mm
- _____ 4 Swivel and brake castors h 128 mm
- _____ Stainless steel shelf GN1/1
- _____ Plastic coated shelf GN1/1
- _____ Stainless steel shelf EN60x40
- _____ Plastic coated shelf EN60x40
- _____ Pair of type L slides 398 mm GN-EN
- _____ Pair of type L slides 398 mm EN
- _____ Sanitizing detergent
- _____ Touch screen kit for storage device control
- _____ Cosmo connection kit

COSMO - wi-fi control

Cosmo is the wi-fi technology that allows VISION blast chillers to be connected, updated and monitored from smartphones. VISION is also a Cosmo hub and allows remote supervision of the Coldline appliances connected to it. From the CosmoApp you can check the operating conditions of each machine and receive alerts in the event of abnormal operation.

Technical draw

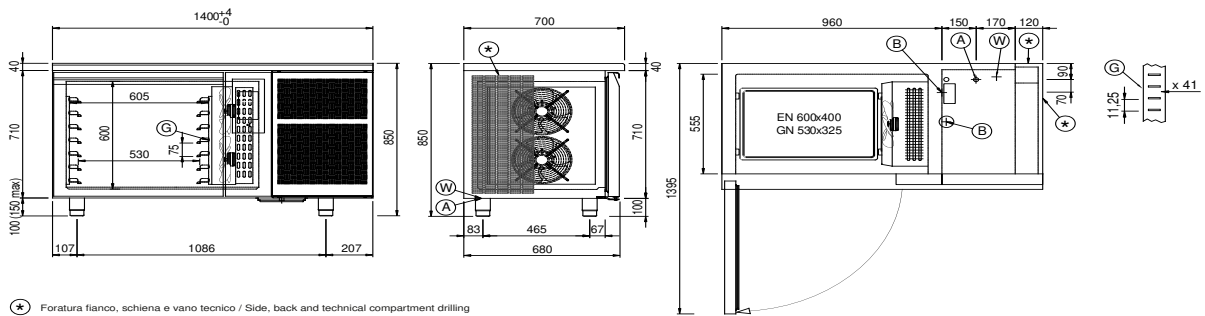

A: Power supply cable outlet

B: Condensation water drain

G: Racks pitch

W: Water mains connection for humidifier - 3/4" female. Unloading not required

In order to constantly offer the best possible products we reserve the right to make changes on technical specifications without incurring any obligation for equipment previously or subsequently sold.