

CPT-66ET

60 MAGICLOTUS

ELECTRIC PASTA COOKERS - TOP

Pasta cooker threephase 25 lts. Tank cm.
51x31x22h. Drain-tap (BASKETS EXCLUDED)



Construction - Fabricated using CrNi 18/10 AISI 304 grade Stainless Steel Scotch-Brite Satin polish Finish, incorporating 1mm thick worktop, rounded edges, chrome details and rear splash back. Tank fabricated in AISI 316. Knobs with waterproof grades IPX5. Model - Professional Electric Pasta Cooker with single tank incorporating built in and floor drain. Perforated pasta baskets with safety handles, available in different sizes for multiple product cooking. Front water drainage tap. High performance tubular heating elements, safety thermostat and 4-position switch control. Security in bowl by water presence sensor. Maintenance - All serviceable parts are accessible by the easy removal of front control panel. Fittings - Appliance is supplied with adjustable feet.



ITALIAN CULINARY ART

The pictures are purely representative. The manufacturer reserves the right to modify the technical data and models without previous notice.

CPT-66ET

60 MAGICLOTUS

ELECTRIC PASTA COOKERS - TOP

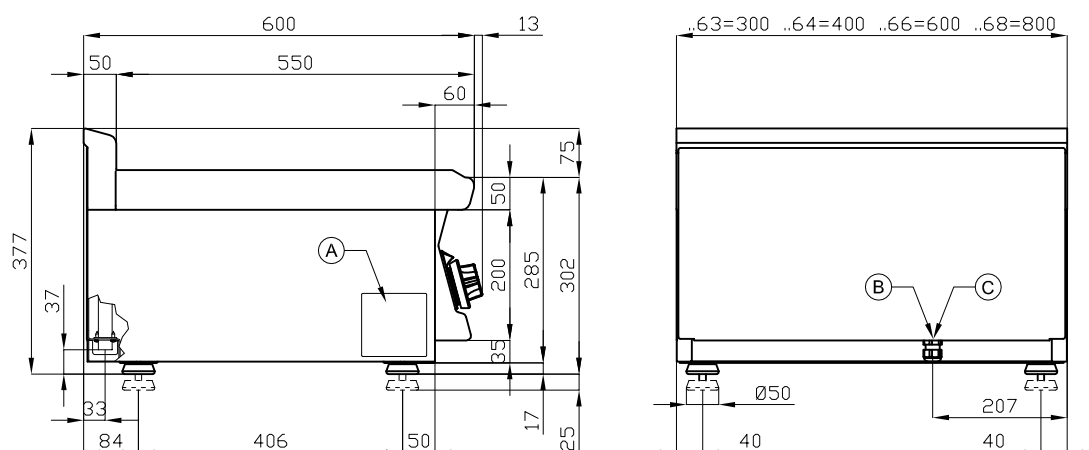

A	Data plate		B	Electrical connection	
---	------------	--	---	-----------------------	--

MODEL: CPT-66ET
DIMENSIONS: cm. 60x 60x 28h
ELECTRIC POWER: 6,25 kW
VOLTAGE: 400V~3N
FREQUENCY: 50/60 Hz



kg: 42
m³: 0.283
mm: 630x690x650

BUY LOTUS BUY ITALY

The pictures are purely representative. The manufacturer reserves the right to modify the technical data and models without previous notice.



LOTUS S.P.A. Via Calmaor, 46
31020 San Vendemiano(TV) - Italy
Tel. + 39 0438 778020 / 778468
Fax + 39 0438 778277
www.lotuscookers.it - lotus@lotuscookers.it