

WD-153 OPTIFLOW

RACK CONVEYOR DISHWASHER



FEATURES

- User-friendly – Ergonomically designed to provide a good working environment
- The WD-Touch display guides you through the washing process with an intuitive touch screen. Easy navigation with built-in user manuals.
- Low operating costs and a reduced environmental impact
- OPTIFLOW-functions:
 - Provides superior control of the dish process
 - Washes and rinses no empty spaces
 - Optimised rinsing water consumption from 0.9 litre of rinsing water per basket regardless of capacity
 - Optimum use of rinsing water with unique double feed
- Triple rinse for reduced final rinse water consumption
- Excellent wash results – Long washing zones with powerful pumps
- Long service life and easy servicing – Made entirely of stainless steel
- Improved hygiene with vertical self emptying wash- and rinse pumps
- Choice of 6 different contact times
- Electrical connection of PRE-RINSE by the dishwasher
- PRE-RINSE using excess water from the dishwasher
- Electricity and water connections from top
- Drain integrated in the machine for easy cleaning and draining
- ECO-FLOW – condensing unit with heat recovery by the exhausted steam
- Wash arms in stainless steel, with quick fit/removal function. Easily cleaned and without endcovers
- Removable doors for the periodical cleaning
- Easy servicing - the machine is serviced from the front
- Singel lever for emptying the tanks, automatic closing of tanks when refilling is starting
- Monitoring system of the machine's various functions
 - Panel which displays the information
- Web Tool with HACCP documentation
- Contactor* for entry and exit conveyor

*Note! It's always necessary to specify the motor power of the conveyor. If not specified, protective motor switch of 0,63-1A will be delivered.

OPTIONS

- Pre-rinse zone L=400 mm
- Drying zone WD-T60 L=600 mm, insulated. Power 3,3 kW.
 - Stand with grid shelf
 - Stand with plane shelf
- Drying zone WD-T80, to turn track L=820 mm, insulated, for connection to the machine together with 90°/180° bar-fedded or machine driven WD turn track. Power 3,3 kW.
- Double drying zone WD-T90 L=900 mm, insulated. With stand. Power 6,6 kW.
 - Grid shelf
 - Plane shelf
- Divided between machine and drying zone
- 230V/3/50Hz
- Marine version and other voltage selection on request
- Steam heated design, steam pressure 50-149 kPa
- Steam heated design, steam pressure 150 - 250 kPa
- Break tank included with booster pump
- Booster heater 12 kW for re-circulating final rinse
- RO-water connection
- Stainless pipes and couplings in final rinse
- Cold water connection
- Water connection from floor
- Timer for pre-rinse
- Timer for through-rinse
- Timer for chain-rinse
- Timer start, machine ready for wash
- Contactor for control of pre-rinse without timer
- Contactor for pre-rinse with booster pump
- Connection power restriction for example Sicotronic
- External power indication
- Auto self cleaning of wash zone
- Auto self cleaning of condens batteri
- Auto self cleaning of wash zone + condens batteri
- Web Tool with HACCP documentation for cost- and consumption report
- Possibility to interlock the booster heater

EXTRA EQUIPMENT

- Conduit for connection cable, L=1200 mm

WASHING ZONES

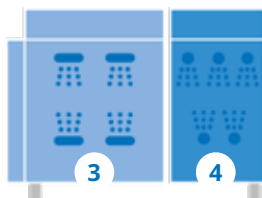

| Zone | Zone length in mm |
|----------------------|-------------------|
| WD-153 | |
| Loading hood | 170 |
| 3 Chemical wash | 900 |
| 4 Triple final rinse | 585 |
| Length | 1655* |

* Installation dimensions at bench height.

| TECHNICAL DATA | WD-153 |
|--|--------|
| Pump, pre-wash (kW) | - |
| Pump, chemical wash 1 (kW) | 1.5 |
| Pump, chemical wash 2 (kW) | - |
| Pump, chemical wash 3 (kW) | - |
| Pump, recirculating final rinse (kW) | 0.11 |
| Fan, heat recovery (kW) | 0.12 |
| Motor, feeder (kW) | 0.12 |
| Booster heater 1 (kW) | 9* |
| Booster heater 2 (kW) | 9 |
| Heater, chemical wash 1 (kW) | 12 |
| Heater, chemical wash 2 (kW) | - |
| Heater, chemical wash 3 (kW) | - |
| Heat recovery unit, cooling area (m ²) | 25 |
| Fan heat recovery, capacity (m ³ /h) | 100 |
| Tank volume, pre-wash tank (litres) | - |
| Tank volume, wash tank 1 (litres) | 100 |
| Tank volume, wash tank 2 (litres) | - |
| Tank volume, wash tank 3 (litres) | - |
| Tank volume, final rinse tank (litres) | 6 |
| Weight, dishwasher in operation (kg) | 490 |
| Degree of protection (IP) | 55 |

* Interlocked if needed, see capacity

| CAPACITY AND OPERATING DATA | WD-153 |
|--|---------|
| Capacity normal wash (baskets/h) | 70-150* |
| Capacity according to DIN 10510 (baskets/h) | 80 |
| Max capacity interlocked booster heater (baskets/h) | 150 |
| Cold water consumption, final rinse normal (litres/basket)** | 1.3 |
| Energy consumption (% of connected power) | 70-90% |
| Steam consumption*** (kg/h) | 50 |
| Environmental temperature at 20°C room temperature (°C) | 35 |
| Sound level**** (dB(A)) | 68 |

* Maximum capacity 260 baskets/h.

** In combination with the PRM the water consumption is further lowered with 0.1 litre

*** For steam-heated dishwasher

**** Measured 1 metre from the side of the machine

| CONNECTION, ELECTRICALLY HEATED DISHWASHER | WD-153 |
|---|--------|
| Total connected power (kW) interlocked booster heater (kW)* | 23.6 |
| Total connected power (kW) | 32.6 |
| Main fuse 400V 3N~(A)** | 50 |
| Max. connection area 400V 3N~(L1-L3, N, PE) Cu (mm ²) | 35 |

* See capacity

** Other voltages on request

| CONNECTION, STEAM-HEATED DISHWASHER 150-250 KPA* | WD-153 |
|---|--------|
| Total connected power (kW) | 1.8 |
| Main fuse 400V 3N~(A) | 16 |
| Max. connection area 400V 3N~(L1-L3, N, PE) Cu (mm ²) | 25 |
| Steam connection (internal thread) | R ¾" |
| Condensation connection (internal thread) | R ½" |

* Other pressures on request.

| CONNECTION, WATER, DRAIN AND VENTILATION | WD-153 |
|--|-----------------|
| Water quality, hardness (°dH) | 2-7 |
| Hot water connection 50-65°C (internal thread) | R ½" |
| Cold water connection 5-12°C (internal thread) | R ½" |
| Drain connection, PP pipe (ø mm) | 50 |
| Water capacity, pressure (kPa) | 250-600 |
| Water capacity, flow (litres/min) | 11 |
| Floor drain, capacity (litres/sec) | 3 |
| Heat load to the room (total, sensible, latent) (kW) | 7.5 / 4.5 / 3.0 |

| SIZE AND WEIGHT FOR TRANSPORT, STANDARD DISHWASHER* | WD-153 |
|---|-------------|
| Size** (LxWxH (m)) | 2.1x0.8x2.0 |
| Weight** (kg) | 400 |

* Normal delivery in 1 piece, If necessary the machine can be further dismantled

** Packaging included

| CONNECTION, ADDITION OF DRYING ZONE | Power (KW) | Main fuse 400V 3N~(A) | Installed length (mm) |
|---|------------|-----------------------|-----------------------|
| Drying zone WD-T60 + WD-153 | 35.9 | 50 | 600 + 1655 |
| Drying zone WD-T90 + WD-153 | 39.2 | 50 | 900 + 1655 |
| Drying zone hood WD-T80 for turn track + WD-153 | 35.9 | 50 | 820 + 1655 |
| Drying zone hood WD-T60F free-standing + WD-153 | 35.9 | 50 | 600 |

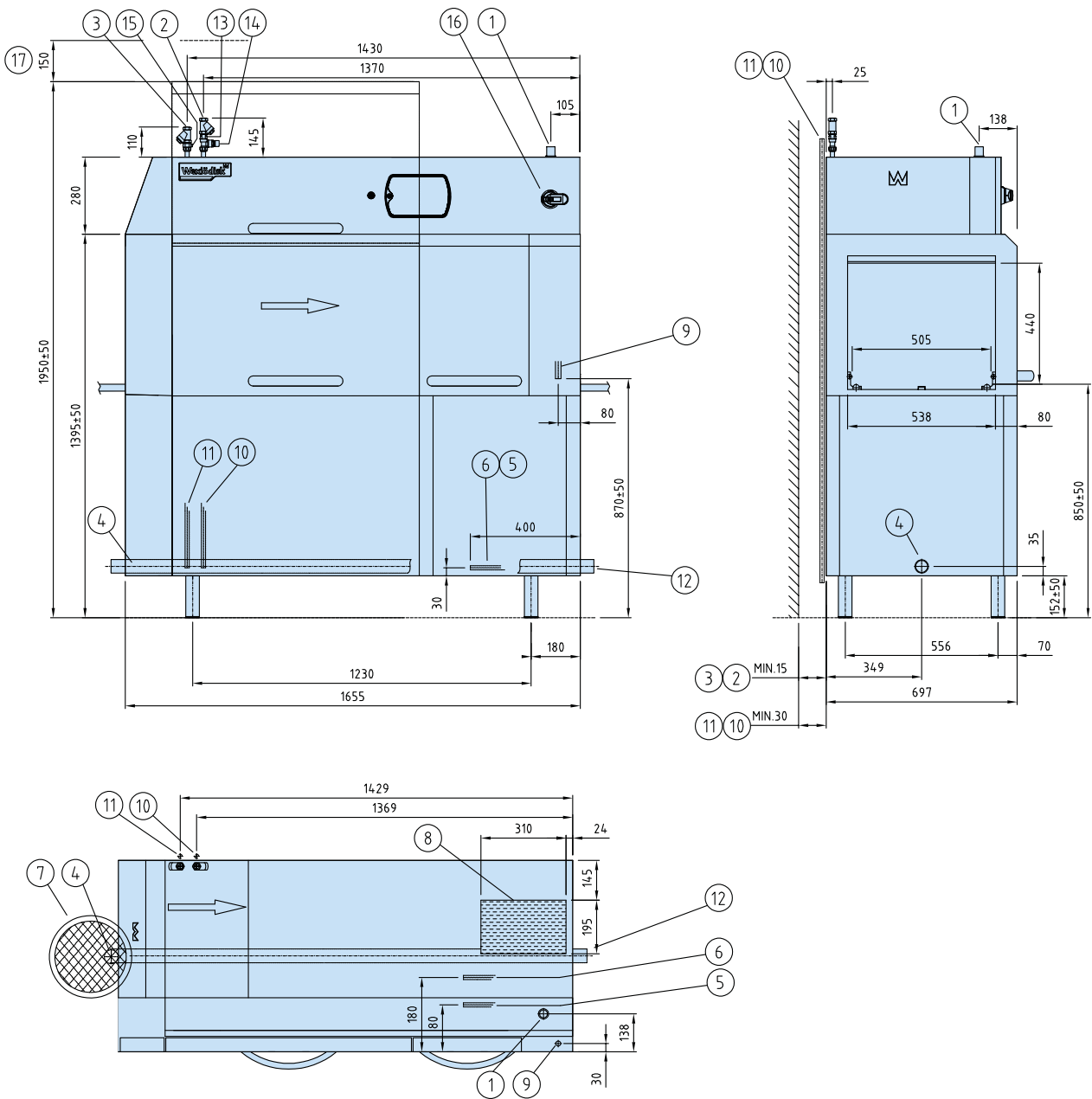

1. Electrical connection
2. Cold water connection/filter R $\frac{1}{2}$ " 250-600 kPa 11 l/min
3. Hot water connection/filter R $\frac{1}{2}$ " 100-600 kPa
4. Drain connection \varnothing 50
5. Steam connection R $\frac{3}{4}$ " (331-421 R") 150-250 kPa
6. Condens water connection R $\frac{3}{4}$ "
7. Sink 3 l/sek
8. Exhaust heat recovery unit
9. Alternative electrical connection
10. Alternative cold water connection R $\frac{1}{2}$ " 250-600 kPa 11 l/min
11. Alternative hot water connection R $\frac{1}{2}$ " 100-600 kPa
12. Alternative drain connection \varnothing 50
13. Non-return valve
14. Vacuum valve
15. Output detergent dosing
16. Main switch
17. Servicing clearance

CONNECTION TO ROLLER TABLE OR BENCH

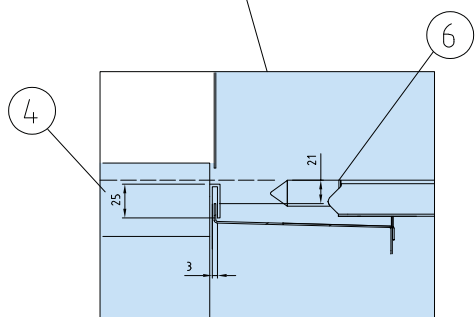
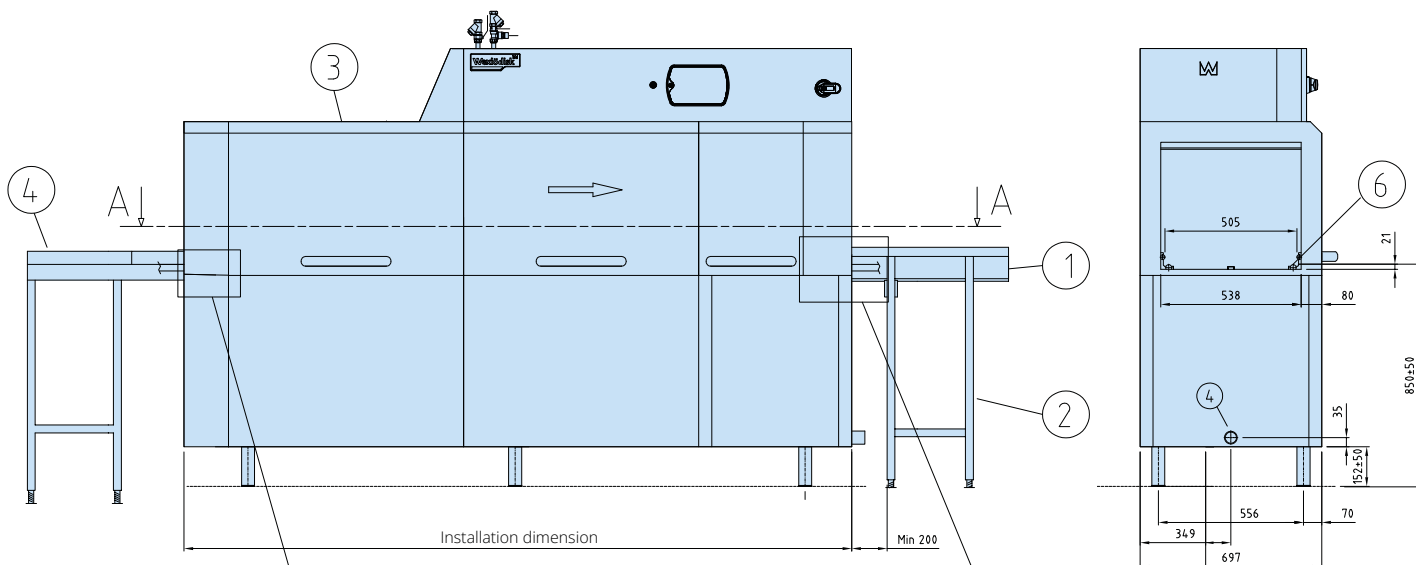

Connection to infeed

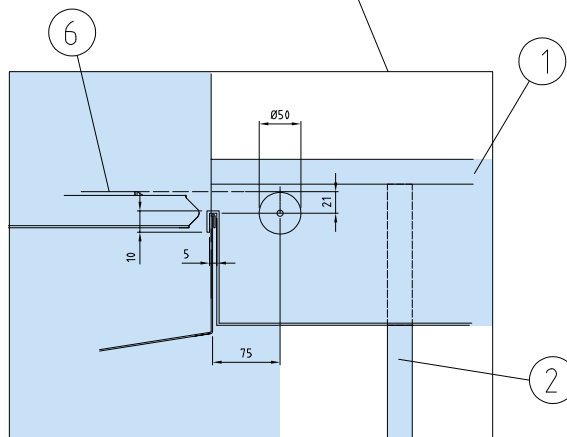

Connection to outfeed

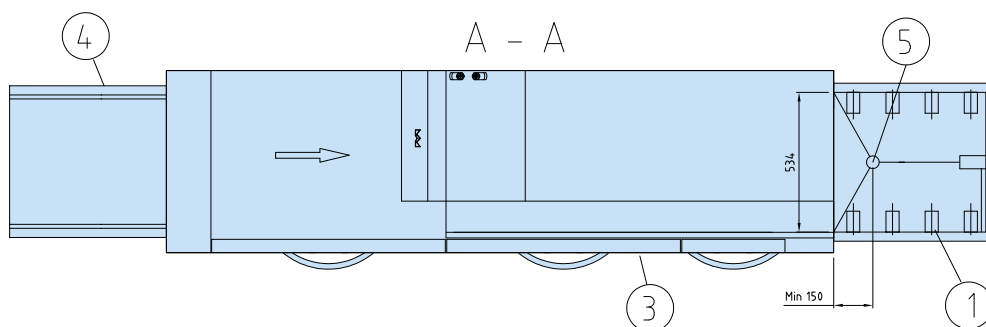

- 1. Roller table
- 2. Leg
- 3. Dishwasher
- 4. Bench
- 5. Drain
- 6. Loading cradle

We reserve the right to change technical data.

Wexiödisk

TELEPHONE: +46 470 77 12 00 FAX: +46 470 237 52 ADDRESS: Mårdvägen 4 SE-352 45 Växjö SWEDEN
E-MAIL: wexiodisk@wexiodisk.com WEBB: www.wexiodisk.com