

# WD-90GR HC

## POTWASHER

- Excellent washing results and fast drying with efficient and energy saving centrifuging spin cycle.
- Perfect for space efficient installations
- No manual pre-wash or scrubbing thanks to heavy rinsing with water and granules
- Stacking of goods can be made directly on the hinged door.
- Unique hexagonal cassette with high capacity for washing containers, holds six ½ or 1/1 containers.
- Wide range of accessories for various items.
- Accessories for washing 65 and 40 mm-deep 2/1 containers and baking trays 600x400 mm.
- Hinged door enables for easy cleaning.
- Six different wash programs with HACCP function.
- Service can easily be made from the front or side



### OPTIONS

- Marine version 400V/3/50 without neutral
- Marine version 440V/3/60 without neutral
- Steam heated design, pressure 50-250 kPa
- Booster pump
- Break tank incl. booster pump
- Stainless couplings in the final rinse
- Connection power restriction
- Connection power restriction Sicotronic
- External power indication
- Web Tool with HACCP documentation and cost- and consumption report

### EXTRA EQUIPMENT

- Table trolley
- Sorting bench
- Holder for accessories, to be placed on the side of the machine
- Hexagonal cassette (1 pc included in the delivery)
- Cassette for canteens with handles
- Cassette for large boxes
- Basket for 4 pc GN 1/1-canteens - 200 mm deep
- Granules 10 kg (included in the delivery)
- Cleaning scraper (1 pc included in the delivery)

### ACCESSORIES TO CASSETTES

- Support for pots and pans 209.7252
- ABC container and lid holder 209.7253
- Support for small pots 209.7254
- Holder for large pots 209.7255 (1 pc included in the delivery)
- Pan holder 209.7268
- Rubber strap 209.7272
- Wire basket for small utensils 209.7278
- Holder for small pots 209.7279
- Flexible insert 209.7283
- Holder for 2/1 containers, grids, baking plates
- 209.7284 (1 pc included in the delivery)

TECHNICAL DATA	WD-90GR HC
Granule pump (kW)	2.2
Rinse pump (kW)	1.5
Motor for the round table (kW)	0.18
Booster heater (kW)	9
Heater tank (kW)	9
Tank volume (litres)	100
Weight, machine in operation (kg)	430
Granule volume (litres)	5
Degree of protection (IP)	IP55

CAPACITY AND OPERATION DATA	WD-90GR HC
Total time/wash program 1** (min)	5.2
Total time/wash program 2** (min)	8.2
Total time/wash program 3** (min)	11
Total time/wash program 4** (min)	2.5
Total time/wash program 5** (min)	4
Total time/wash program 6** (min)	7
Capacity, max (1/1 containers/program)****	6
Capacity / h, Pr 1 (1/1-containers) incl. handling ****(pc)	68
Capacity / h, Pr 1 (1/2-containers) incl. handling ****(pc)	68
Cold water consumption rinse/program (litres) *****	3.5-5

CAPACITY AND OPERATION DATA	WD-90GR HC
Water consumption cooling/program (litres) *****	0-1.5
Energy consumption (% of connected power)	70-90%
Steam consumption *** (kg/h)	15
Sound level* (dB(A)) washing program with granules	69
Max. surface temp. at room temp. 20°C (°C)	30

\* A-weighted sound pressure level, L<sub>pA</sub>

\*\* Factory setting. The wash time is adjustable

\*\*\* Steam heated machine

\*\*\*\* Max. capacity depending on the depth of the containers.

\*\*\*\*\* Applies under ideal conditions and program using spinning.

The water consumption depends on local conditions. An exact adjustment is made during installation.

CONNECTION, ELECTRICALLY HEATED MACHINE	WD-90GR HC
Total connected power (kW)	11,3
Main fuse 400 V, 3N~ (A)*	20
Max.conn.area 400 V, 3N~, (L1-L3,N,PE) Cu (mm <sup>2</sup> )	6

\* Other voltages on request

CONNECTION, STEAM HEATED MACHINE 50-250 KPA	WD-90GR HC
Total conn.power (kW)	2,4
Main fuse 400 V, 3N~(A)*	16
Max.conn.area 400 V, 3N~, (L1-L3, N, PE) Cu (mm <sup>2</sup> )	6
Steam connection (internal thread)	R½"
Connection condense water (internal thread)	R½"

\* Other voltages on request

CONNECTION WATER, DRAIN AND VENTILATION	WD-90GR HC
Water quality, hardness (°dH)	2 - 7
Cold water connection 5-12°C (internal thread)	R½"
Hot water connection 55-70°C (internal thread)	R½"
Drain connection, PP pipe (ø mm)	50
Water capacity warm water, pressure (kPa)	250
Water capacity warm water, flow (litres/min)	15
Water capacity cold water cooling, min/max pressure (kPa)	100/600
Floor drain, capacity (litres/sec)	3
Ventilation of the machine (m <sup>3</sup> /h)	600

SIZE AND WEIGHT FOR TRANSPORTATION	WD-90GR HC
Size * LxWxH (mm)	1060x900x1950
Weight * (kg)	340

\* Packaging included

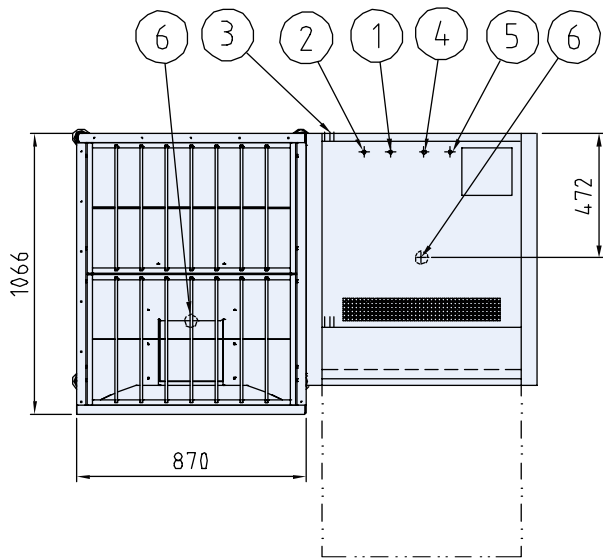
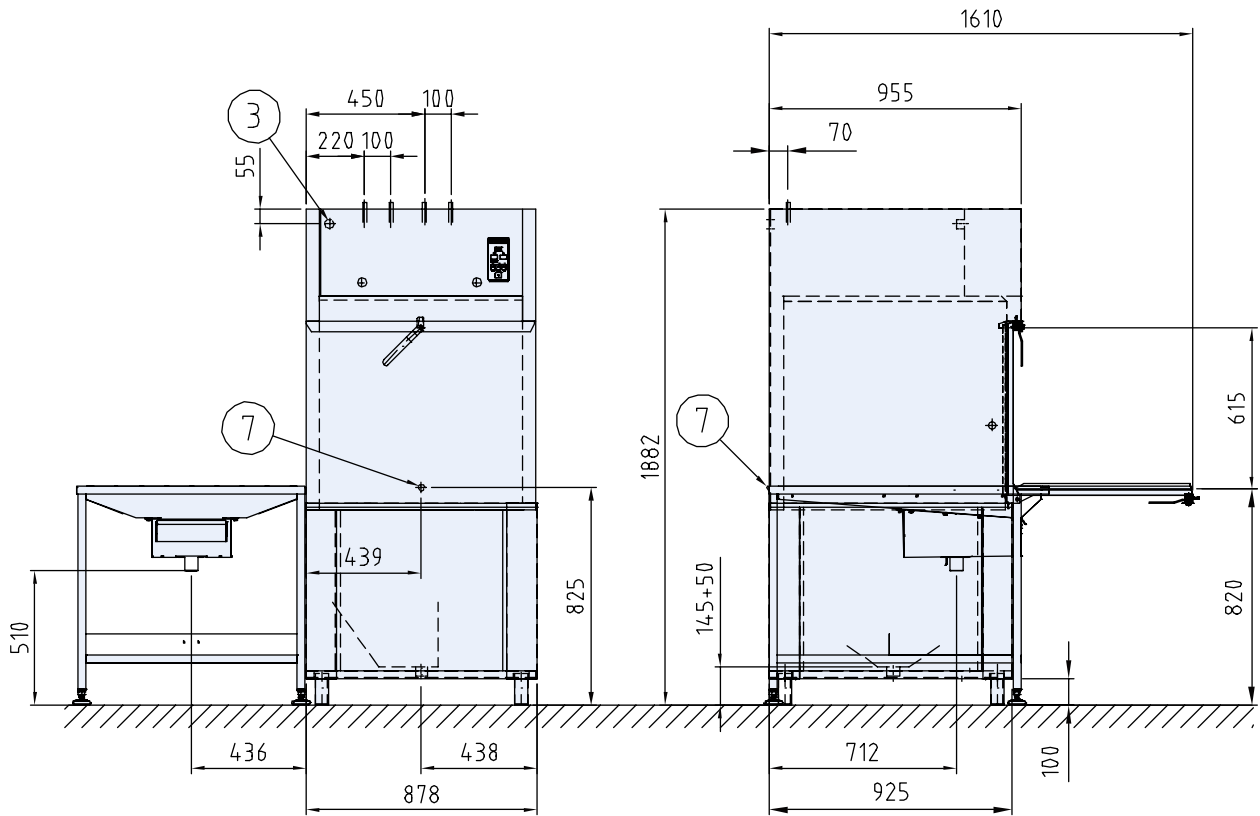

1. Cold water connection
2. Hot water connection
3. Electrical connection
4. Steam connection (steam-heated machine)
5. Condensation water connection (steam-heated machine)
6. Drain connection
7. Detergent connection

We reserve the right to change technical data.

# A selection of accessories for WD-90GR HC



Hexagonal cassette, part. no. 209.7285  
Included in the delivery.



Pot holder, part.no. 209.7255  
For large pots. Included in the delivery.



Grid, part. no. 209.7284  
For 2/1 containers, grids, baking plates.  
Included in the delivery.



Utensil holder, part. no. 209.7251  
For hexagonal cassette and round  
basket.



Flexible insert, part. no. 209.7283  
Rubber rope holder for bowls and pots.



Pot holder for small pots, part. no.  
209.7254



Pot holder, part. no 209.7268  
For frying plates and pots.



ABC- and lid holder, part. no. 209.7253



Basket for ABC containers,  
part. no. 209.7259

The following accessories are included as standard:

Hexagonal cassette	Part. no. 209.7285	1 pc
Pot holder	Part. no. 209.7255	1 pc
Grid for 2/1 container	Part. no. 209.7284	1 pc

Other additional equipment for other kind of  
dishes can be requested.

## Wexiödisk