

Trolley washer

■ WD-18 CW



Wexiödisk 

BECAUSE WE DO CARE



Every installation must result in a good reference!

www.wexiodisk.com

WD-18 CW

The flexible trolley washer for hospitals, flight catering and larger institutions.



The trolley washer conquers the world



The WD-18CW trolley washer has been developed to meet the high industrial requirements of customers within the airline catering industry. Requirements such as excellent hygiene, high capacity and low operating costs made it impossible to use conventional technology. The result is a machine that can easily clean the majority of trolleys and other items used within the catering industry.

Today, the WD-18CW is used not only by airline caterers, but also by hospitals and central kitchens around the world.

- **High capacity**
30 – 40 washing cycles/hour.
- **Easy handling**
One person can easily operate the machine.
- **Improved working conditions**
Low noise level and better ergonomics.
- **Flexible**
Washes numerous different trolleys and items.
- **Low operating cost**
Minimal energy and water consumption.
Only 6 litres of water per cycle and drying without heat.
- **Excellent washing and drying results**
Unique washing process with rotating items dried using centrifugation.
- **Customised dishwashers**
We also offer custom design for special needs.

Compact och flexible with high capacity

The WD-18CW is able to cope with many different items and trolleys. It is excellent at washing bulky items, such as catering trolleys, tray trolleys, dispenser trolleys, rack trolleys, transport trolleys and various other heavily soiled items. Some examples are shown on the next page. The machine also takes up little floor space, just 4.5 m².

The high capacity of WD-18CW means it can perform 30 – 40 washing cycles/hour. There are three different washing programmes. The shortest one takes only 95 sec. The machine is spacious and the internal dimensions of the washing compartment are 1,070 x 1,030 mm, height 1,850 mm, which means that several trolleys can normally be washed together, depending on their size.

Having considered the demanding working conditions normally associated with dish-washing areas, we have put significant emphasis on improving this working environment. For example, no hot air is discharged into the work area during the drying process, which ensures a better indoor climate and reduces demands on ventilation and air conditioning systems. The machine also has a very low noise level.

Compared with the manual washing of trolleys, the WD-18CW trolley washer ensures better ergonomics and reduced contact with chemicals and eliminates the risk of accidents, as trolleys do not need to be rinsed or dried in the work area.



One person can easily handle the machine. As the doors operate automatically, it is easy to load and unload the machine. Just push at button to start the washing. The machine's display shows the progress of the washing cycle.

Low operating cost – just 6 litres of water per cycle

Years of development work have led to a balance between optimum machine performance and minimal impact on the environment.

The WD-18CW trolley washer uses just 6 litres of fresh water per washing cycle. Consumption of electricity and chemicals is also very low. Compare that with manual cleaning of trolleys - the most common alternative to a trolley washer - which uses between 20 and 50 litres of hot water per trolley, plus detergent. Additional savings are possible by using the exhaust ventilation air to heat the incoming cold water.

Excellent washing and drying results

Unique technology is used to produce excellent washing and drying results within a very short time. Fixed rinse arms in combination with rotating items ensure even the most hard-to-reach areas are cleaned.

Drying uses spin-dry to ensure that no water is left anywhere on the trolley, e.g. behind handles, doors, hinges, etc. No heat is supplied during drying, as the increased rotation speed helps items dry naturally. This means there is no need for an additional hot air supply.

We customise

The machine is supplied as standard with fittings suitable for items of varying shapes and sizes. Items that fit within a circle of 1,600 mm (diameter) can very likely be washed. We also offer custom design for customers using items with different dimensions.



Monitoring and information

The unique monitoring system, WEB Tool, has been developed to allow washing to be made more efficient, reduce the environmental impact, and to minimise operating costs.

The WEB Tool connects the individual dishwasher to the network and PC. A standard web browser creates reports, and monitoring of the dishwasher's HACCP information, costs, water and electricity consumption is performed in order to satisfy all the applicable HACCP hygiene requirements.

The function ensures an optimal hygienic wash result, which is documented and saved in the machine, and which can be printed as required.



▶
 Examples of the different types of trolley and other items that can be washed. Please note that trolleys and other wheeled items do not need to be secured. The rotation action means they will be pressed against the inside of the rotating cage. All you need to do is wheel the items in, close the door and start the washing cycle!



Max weight 250 kg.

■ Technical data WD-18CW

Technical data	WD-18CW
Wash pump (kW)	2.2
Return pump (kW)	1.2
Motor turn table (kW)	0.55
Condensing fan (kW)	1.1
Drive motor roller doors (kW)	2x0.18
Booster heater (kW)	12
Heater tank (kW)	36
Heat recovery unit, cooling area (m ²)	51
Fan heat recovery, capacity (m ³ /tim)	1,000
Tank volume (litres)	200
Weight, machine in operation (kg)	1,450
Degree of protection (IP)	55

Capacity and operating data	WD-18CW
Total time/wash program 1 (min)*	1.2
Total time/wash program 2 (min)*	1.6
Total time/wash program 3 (min)*	2.0
Total time/wash program 4 without spin dry (min)*	1.0
Total time/wash program 5 without spin dry (min)*	1.4
Total time/wash program 6 without spin dry (min)*	1.8
Max. capacity, baskets/hour (no.)	50
Package size for dish ware with standard interior (mm)	H=1850 W=1070 L=1030
Max weight dish ware with standard interior (kg)	250
Water consumption rinse/program (litres)	6
Compressed air consumption (litres/min)	50
Energy consumption** (% of connected power)	70-90
Steam consumption (kg/h)**	90
Environmental temperature at 20°C room temperature (°C)	35
Sound level (dB (A)) ***	65

* Factory setting. The wash time is adjustable.

** Steam heated machine.

*** Measured 1 metre from the machine.

Connection, electrically heated machine	WD-18CW
Total connected power (kW)	52.5
Main fuse 400V 3N~ (A)*	80
Max.conn.area 400V 3N~ (L1-L3,N,PE) Cu (mm ²)	70

Connection, steam heated machine 150-250 kPa**	WD-18CW
Total conn. power (kW)	4.5
Main fuse 400V 3N~(A)*	20
Max.conn.area 400V 3N~(L1-L3, N, PE) Cu (mm ²)	35
Steam connection (internal thread)	R 1 1/4
Connection condense water (internal thread)	R 3/4

* Other pressure on request.

** Other voltage on request.

Connection water, drain and ventilation	WD-18CW
Water quality, hardness (°dH)	2 - 7
Hot water conn. 55-70°C (internal thread)	R 3/4
Cold water conn. 5-12°C (internal thread)	R 3/4
Compressed air 600kPa (internal thread)	R 1/2
Drain connection, PP pipe (ø mm)	50
Water capacity cold water, pressure (kPa)	300
Water capacity cold water, flow (litres/min)	30
Water capacity hot water min/max pressure (kPa)	100/600
Floor drain (litres/sec)	3
Heat load to the room (total, sensible, latent) (kW)	11 / 6.5 / 4.5

Size and weight for transportation**	WD-18CW
Size complete machine* (LxWxH (m))	2.6x2.0x2.75
Weight complete machine* (kg)	1,350
Package size part 1* (LxWxH (m))**	2.6x2.0x2.25
Package size part 2* (LxWxH (m))**	1.9x2.05x0.8
Weight part 1* (kg)**	850
Weight part 2* (kg)**	580

* Packaging included.

** Delivery in 2 pieces. If necessary the machine can be further dismantled.

Alternative installations

1. Single-door / through-fed model

The machine can be supplied as a one or two-door model, depending on the layout in question.

The single door version is suitable for narrow spaces where loading and unloading are performed from the same side. Layout permitting, the WD-18CW can be fitted with two doors (clean and dirty side), i.e. a through-fed machine.

2. Floor mounted or pit mounted model

The machine can be installed in two ways;

A. Standing on an existing floor, with no specific demands on the building. Ramps are included.

B. Pit mounted. Loading and unloading is performed at the same level as the floor. Suitable for new installations.

■ Dimensional drawings - floor mounted

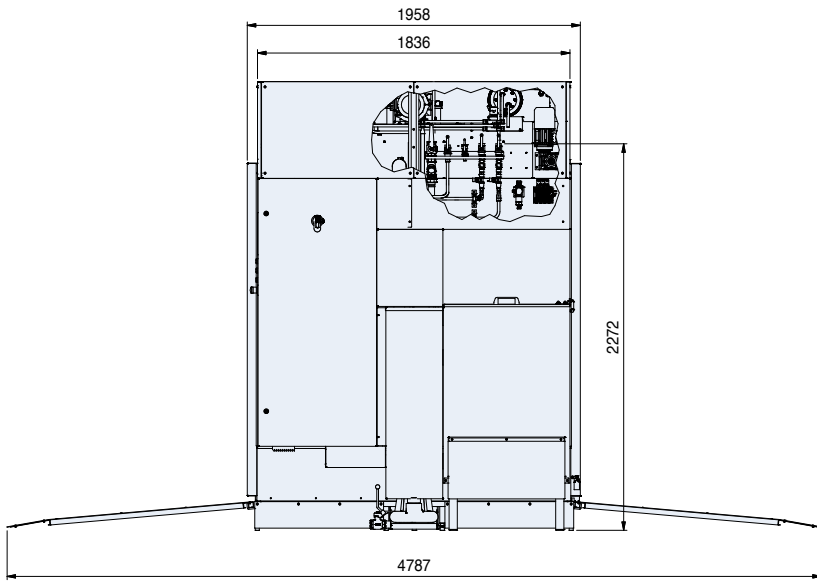

1. Hot water DN20, 30 l/min, 300 kPa
2. Cold water DN20, 30 l/min, 300 kPa
3. Compressed air DN15, 600 kPa, 50 l/min
4. Condensate DN20
5. Steam DN32, 150-250 kPa, 90 kg/h
6. Electrical connection 52,5 kW (el.heating)
4,5 kW (steam heating)
7. Ventilation connection Ø160 mm,
2000 m³/h (60sec./program)
8. Floor drain (200 l/min)

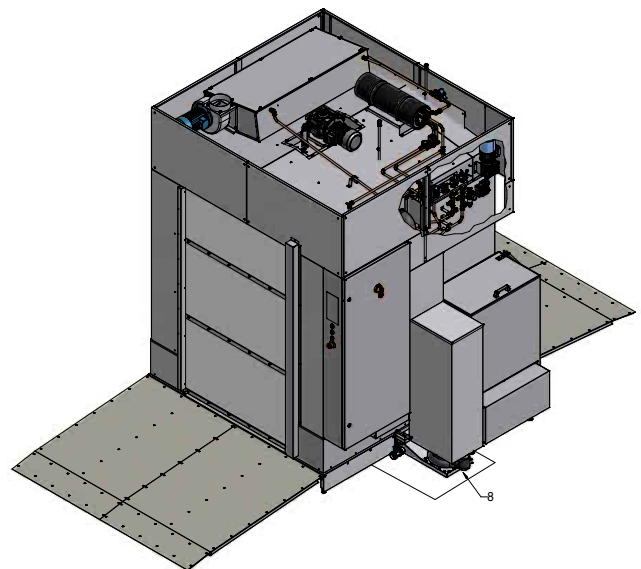
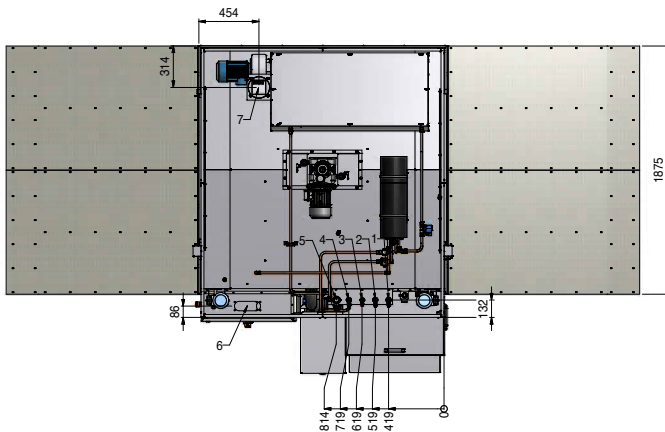
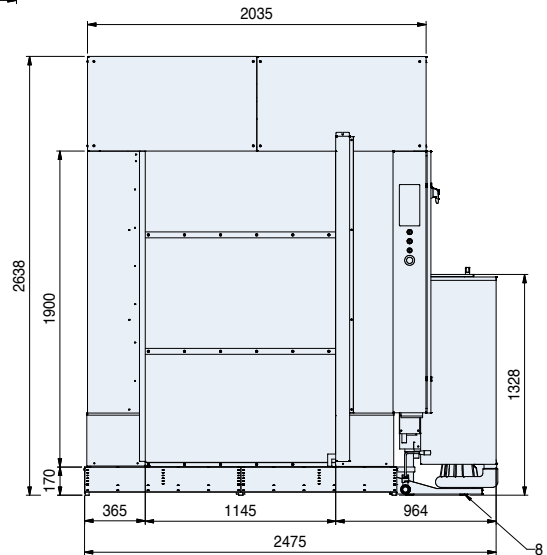

Dimensional drawings - pit mounted model

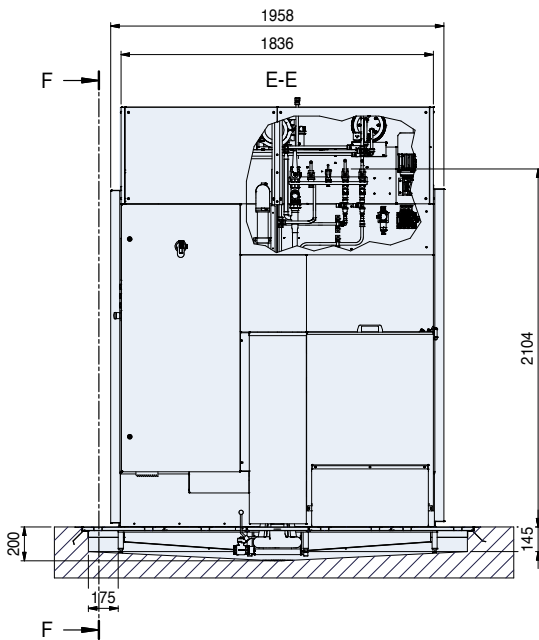

When installed pit mounted, a mounting frame and cover plates are included in the delivery. The recess in the floor must be 200 mm deep.

1. Hot water DN20, 30 l/min, 300 kPa
2. Cold water DN20, 30 l/min, 300 kPa
3. Compressed air DN15, 600 kPa, 50 l/min
4. Condensate DN20
5. Steam DN32, 150-250 kPa, 90 kg/h
6. Electrical connection 52,5 kW (el.heating)
4,5 kW (steam heating)
7. Ventilation connection Ø160mm, 2000 m³/h
(60sec./program)
8. Floor drain (200 l/min)

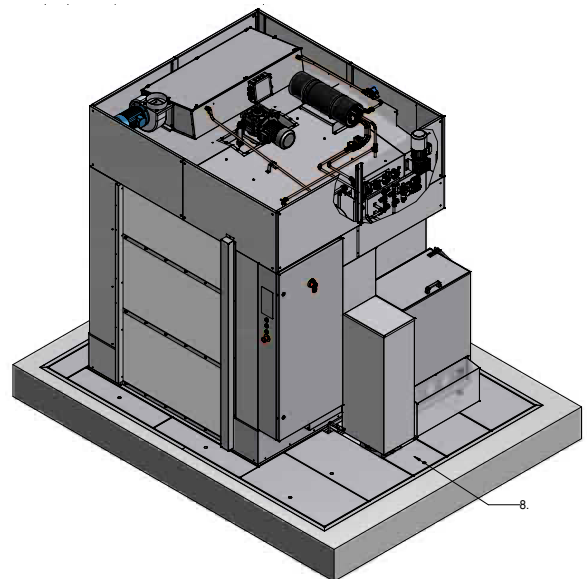
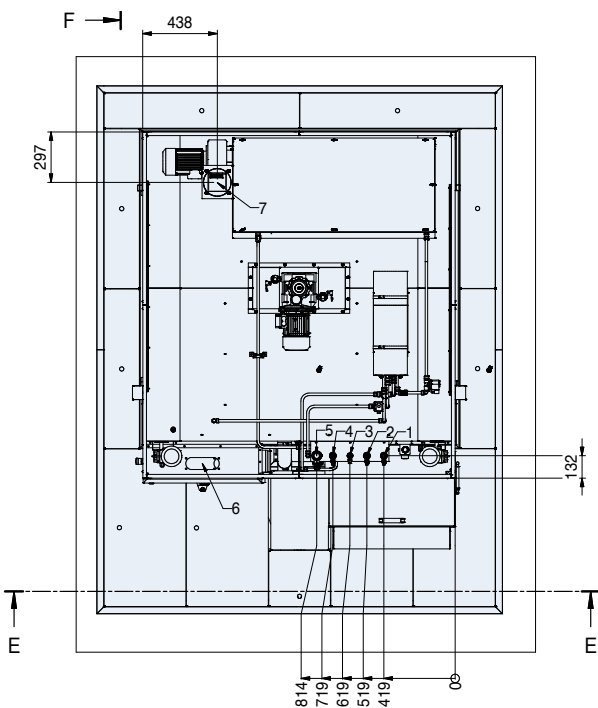
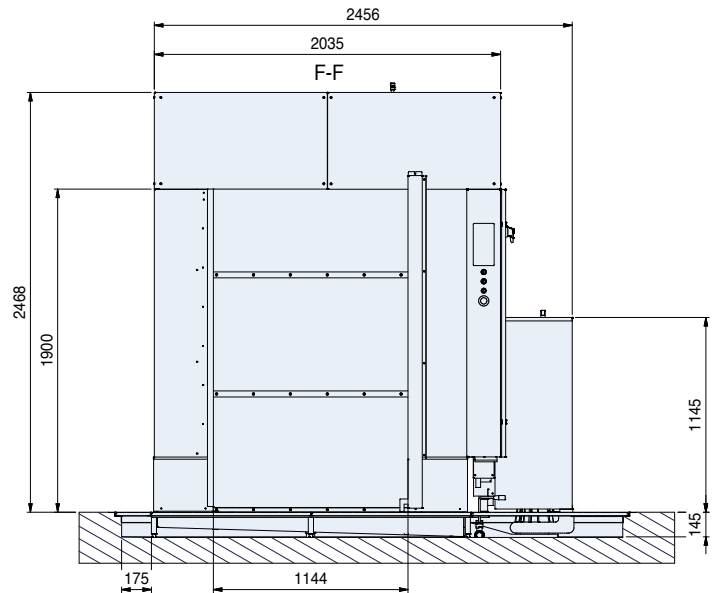

BECAUSE WE DO CARE

Telephone: +46 470 77 12 00
Telefax: +46 470 237 52
Address: Mårdvägen 4
SE-352 45 Växjö
SWEDEN
E-mail: wexiodisk@wexiodisk.com

Wexiödisk 

www.wexiodisk.com