



IMMERSION CIRCULATOR SMARTVIDE XL

Maximum capacity: 120 l / 30 gal.



FOOD PRESERVATION AND SOUS-VIDE
SOUS-VIDE COOKERS

SALES DESCRIPTION

Commercial high-precision sous-vide cooker. Reliable, user-friendly, portable. Interchangeable between °C and °F.

- ✓ Bluetooth / WIFI connectivity.
- ✓ HACCP-ready.
- ✓ Optional core probe and temperature control by core probe.
- ✓ Firmware update.
- ✓ 5" colour touch screen.

Portable precision cooker with stirrer for up to 120 lt. / 30 gal. containers. Designed for chefs, developed with chefs.

- ✓ The thick stainless steel, robust construction guarantees commercial performance.
- ✓ SmartVide guarantees cooking at a **precisely controlled temperature** while preserving the quality of the product, enhancing flavor and texture. Equipped with a highly precise temperature control system to obtain extremely consistent results.
- ✓ The **optional core probe** allows for an even more precise control when standardizing recipes. Recipes can be set and the SmartVide controlled by the core probe temperature.
- ✓ Allows cooking food in their own juice and using this juice immediately after cooking to **enhance flavors**.
- ✓ Marinates and macerates an ingredient in **half the time**.
- ✓ **Infuses and flavors** oil, fat or other products applying the controlled temperature technique.
- ✓ The possibility of probe activated cycle start is a crucial function for **pasteurization**.
- ✓ The possibility of connecting SmartVide XL to an enhanced tank reduces heating time. This function is specially useful when cooking or retherming very cold or frozen food.
- ✓ Increases **profits** due to lack of product shrink. Requires **very little hands-on time**, allowing the Chef to do other tasks while the pro-

duct is being cooked. Just program temperature and time, SmartVide will do the rest. The interactive full-color touchscreen offers **all information at a glance** and makes operation extremely intuitive. In addition, thanks to the connectivity, an exchange of important data is allowed to improve the performance of the Chef.

- ✓ SmartVide XL offers a complete **settings menu**, accessible through its touch screen.
- ✓ **Portable**: thanks to their thick, stainless steel, ergonomic handle, SmartVide can be taken from a container to another easily.
- ✓ **HACCP-ready**: thanks to Bluetooth connectivity, it is possible to export or print cooking results at the end of each cycle. Furthermore, the cooking data be consulted on the interactive touch screen at any time **during** the cycle.
- ✓ **Your appliance, always updated**: free firmware update, no matter where the appliance is with no need of additional appliances.

INCLUDES

- ✓ Janby Track Mini (must be activated).

OPTIONAL

- Core probe.
- Insulated tanks.
- Heated tanks.
- Lids for insulated tanks.
- Floating balls.
- Janby Track (available through janby.kitchen).

ACCESSORIES

- Heated tanks for SmartVide X
- Baskets for 120P heated tank
- Heated tanks for SmartVide XL

SPECIFICATIONS

Temperature

Display precision: 0.01°C

Range: 5°C - 95°C

Permissible ambient temperature: 5°C - 40°C

Time

Resolution: 1'

Cycle duration: 1' - 99 h

General features

Maximum recipient capacity: 120 l

Total loading: 2600 W

Submersible part dimensions: 117 mm x 110 mm x 197 mm

External dimensions (W x D x H): 125 mm x 148 mm x 435 mm

Net weight: 4,65 kg

AVAILABLE MODELS

1180402 SmartVide XL 208-240/50-60/1

1180400 SmartVide XL 230/50-60/1

1180406 SmartVide XL 230/50-60/1 AUS

* Ask for special versions availability



product sheet
updated 30/01/2024



IMMERSION CIRCULATOR SMARTVIDE XL

Maximum capacity: 120 l / 30 gal.



FOOD PRESERVATION AND SOUS-VIDE
SOUS-VIDE COOKERS

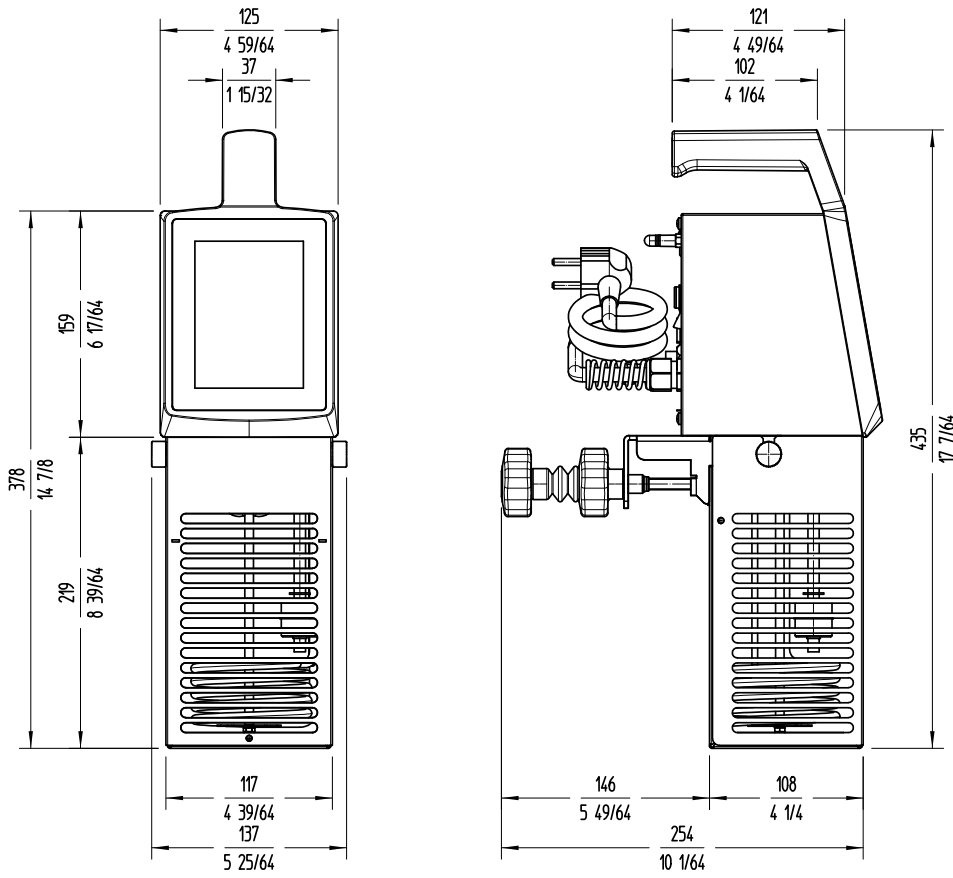

sammic | www.sammic.com
Food Service Equipment Manufacturer

Polígono Basarte, 1. phone +34 943 15 72 36
20720 Azkoitia, Spain sales@sammic.com



Project	Date
Item	Qty
Approved	

product sheet
updated 30/01/2024